

Split air conditioner Wall mounted Type Service manual

AUS-07H53F010Px

AUS-07C53F010Px

AUS-09C53F010Px

AUS-09H53F010Px

AUS-12H53F110Px

AUS-12C53F150Px

AUS-12H53F150Px

(X=1,2,3,.....)



Большая библиотека технической документации

<https://splitsystema48.ru/instrukcii-po-ekspluatatsii-kondicionerov.html>

каталоги, инструкции, сервисные мануалы, схемы.

CONTENTS

| | |
|--------------------------------------|----|
| Contents..... | 1 |
| Safety precautions..... | 2 |
| Installation..... | 2 |
| Block diagram..... | 11 |
| Trouble shooting..... | 12 |
| Fault diagnosis by symptom..... | 13 |
| Control specification..... | 17 |
| To disassemble mechanical parts..... | 23 |
| Exploded views and parts list..... | 27 |
| Wiring diagrams..... | 39 |

SAFETY PRECAUTIONS

The following safety precautions must be taken when using your air conditioner.

1. Warning: Prior to repair, disconnect the power cord.
2. Use proper parts: use only exact replacement parts. (Also, we recommend replacing parts rather than repairing them.)
3. Use the proper tools: use the proper tools and test equipment, and know how to use them. Using defective tools or test equipment may cause problems later-intermittent contact, for example.
4. Power cord: prior to repair, check the power cord and replace it if necessary.
5. Avoid using an extension cord, and avoid tapping into a power cord. This practice may result in malfunction or fire.
6. After completing repairs and reassembly, check the insulation resistance.
Procedure: prior to applying power, measure the resistance between the power cord and the ground terminal. The resistance must be greater than 30 megohms.
7. Make sure that the grounds are adequate.
8. Make sure that the installation conditions are satisfactory. Relocate the unit if necessary.
9. Keep children away from the unit while it is being repaired.
10. Be sure to clean the unit and its surrounding area.

INSTALLATION

Selecting area for installation

Select an area for installation that is suitable to the customer's needs.

1 Location of indoor unit

- Keep the air inlet and outlet at a far distance from the blockage.
- Keep the height distance between the indoor and outdoor unit at most 5m.
- Mount on the wall solid enough to bear the weight of the unit and not cause any shake.
- Avoid direct sunshine.
- A place easy for condensate drain and easy for connecting with the outdoor unit.
- Keep a far distance away from the fluorescent lamp, it may influence the operation of remote controller.
- Keep at least 1m away from the TV radio and other home appliances.

2 Location of outdoor unit

- A place solid enough to bear the weight of the unit and not cause any shake.
- Good ventilation, less dust, far from direct rain and sunshine.
- A place where the air discharged out of the outdoor unit or the operation noise will not annoy your neighbours.
- No blockage near the outdoor unit.
- Avoid places close to inflammable gas leakage.

Caution:

It is harmful to the air conditioner if it is used in the following environments: greasy areas (including area near machines). Salty area such as coastal areas, areas where sulfuric gas is present such as hot spring areas. Contact your dealer for advice.

INSTALLATION

Installation diagram of indoor unit and outdoor unit

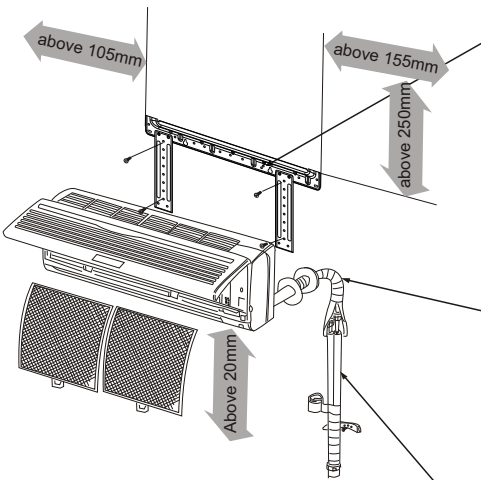

Confirm the installation position by the mark of the indoor mounting plate.

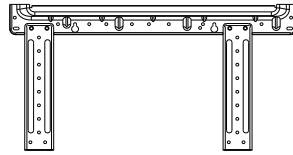

Note: Different models have different mounting plates, the installing charts of this book are presented just for the purpose of illustration, please take the real objects as reference.

The connecting pipe can be led from back, right, underside, or left-back side.

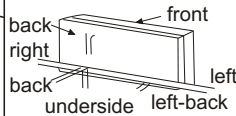

Notice: do not raise the drain hose.

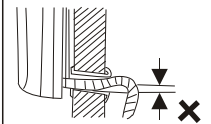

Attention:

The allowable length of the connecting pipe is 10m.
The allowable distance between indoor unit and outdoor unit is 5m.

While installing the pipeline on the thin armor plate or on the wall of metal mesh, you should use the wooden board to clamp between the wall and the pipeline, or wrap up the pipeline with 7-8 layers of insulating plastic tape.

Cover connecting pipe with adiabatic material.



Sponge plastic adiabatic material with the thickness of 8mm.

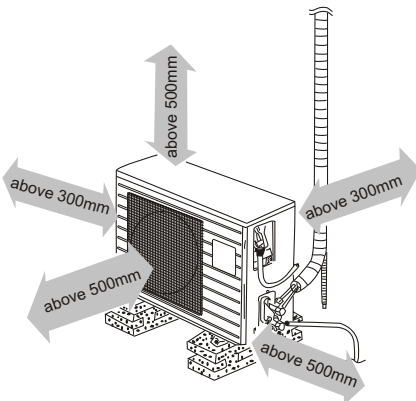

INSTALLATION

1 Securing the mounting plate and drill on the wall

Note: Different models have different mounting plates, the installing charts of this book are presented just for the purpose of illustration, please take the real objects as reference.

- **Secure the mounting plate**

The mounting plate should be attached to the structural part of wall (post etc).

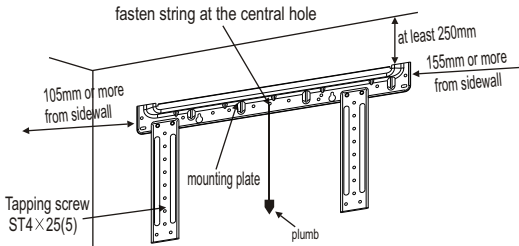

- NOTICE:**
- The holes at solid arrow position must be secured to avoid the shake of mounting plate.
 - When the expansion bolts are used, two holes (11×20 or 11×26) that the distance between them is 450mm should be adopted.

- **Drill on the wall**

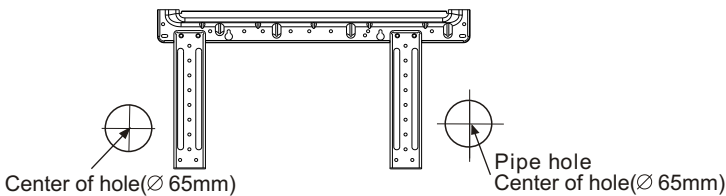

Operation:

1. Confirm the position of the wall hole according to the chart (If it need to orientat a hole on the left side of the mounting plate, please refer to the method of orientating the right wall hole in the above chart).
2. Use the aiguille to drill a hole with a diameter of 65mm .

INSTALLATION

2 Wiring

- Open the front grille;
- Remove the screw from electrical box cover, pull the electrical box cover away from the unit and set aside.
- Remove the screw from fastener, pull the fastener away from the unit and set aside.
- Connect the cable.
- Replace the fastener and electrical box cover.

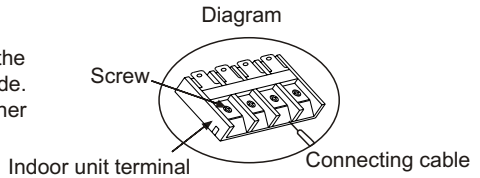

NOTE:

The appliance shall be installed in accordance with national wiring regulations.

The appliance must not be installed in the laundry.

The appliance must be installed 2.3m above the floor.

The appliance must be positioned so that the plug is accessible.

For some models whose cooling capacity are above 4600W (17000BTU/h), an all-pole disconnection device which has at least 3mm separation distance in all pole and a residual current device(RCD)with the rating of above 10mA shall be incorporated in the fixed wiring according to the national rule.

3 Installation of the drain hose

NOTE:

- The drain hose must be arranged beneath the copper pipe.
- The drain hose must not be hunched or twisted.
- While wrapping up the drain hose, do not pull it.
- The drain hose through the room must be wrapped up by the thermal insulation materials.
- The copper pipe and the drain hose must be wrapped up by felt strip. Adiabatic pad should be used at where the pipe contacts the wall.

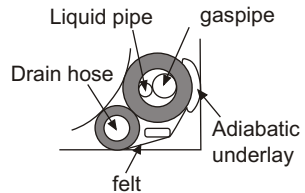

ROUTE OF PIPE

- If pipe comes out of the right side of the indoor unit, cut part "1" of the unit;
- If pipe comes out of the lower-right side of the indoor unit, cut part "2" of the unit;
- If pipe comes out of the left side of the indoor unit, cut part "3" of the unit.

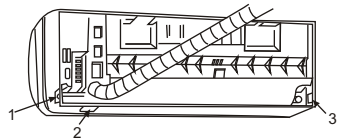

REFIT OF DRAIN HOSE

- If pipe comes out of the left side of the indoor unit, the drain hose must be refitted, otherwise water leakage may occur.
- Refit methods: Interchange the position of drain hose and drain rubber plug.
- Clearance is not allowed after refit, it would lead to water leakage.

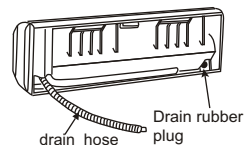

INSTALLATION

Arrangement of the drain hose

- To drain the condensate water easily, the drain hose should be declined downwards. The following 5 arrangement methods are incorrect.

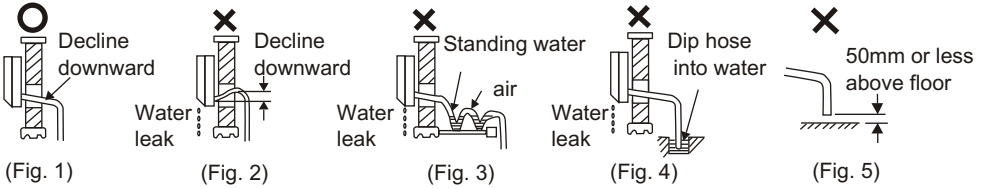

- If you find the drain hose not long enough to connect with the indoor unit, you can extend it with the hoses in the accessory box.
- The drain hose through the room must be wrapped up with the special adiabatic material.

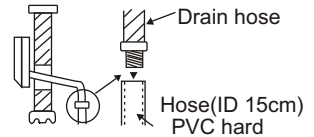

4 Installation of the indoor unit

Let pipe go through the wall hole and attach the indoor unit to the mounting plate. (Press the rib of indoor unit inside the hook of the mounting plate.)

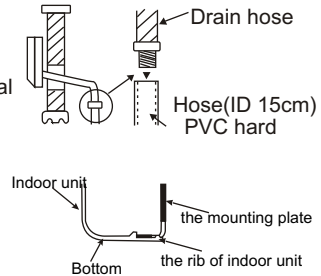

5 Pipe Connection

- The number of bent position of the pipe in the indoor unit should not exceed 10.
- The number of bent position of the pipe in the indoor unit and the outdoor unit should not exceed 15.
- The radius of bent position should be more than 10cm.
- Please break the evaporator craft tube with pincers before connecting. After exhausting the inside air, use the wrench to twist down the nut of connecting tube of the evaporator.
- Put some seal oil to cover the joint and the flare.
- Align the centre of joint in line with that of flare and tighten the nut of connecting pipe with wrench.

Attention:

Do not exhaust the inside air just by loosing the nut since there is the air of certain pressure inside the tube of indoor unit. Please do not make extra effort for fear of damaging the flare.

| DIAMETER OF PIPE | TORQUE (N · m) |
|------------------|----------------|
| 6.35mm (1/4") | 13.7--17.6 |
| 9.52mm (3/8") | 34.3--41.2 |
| 12.7mm (1/2") | 49.0--56.4 |
| 15.88mm (5/8") | 73.0--78.0 |



6 Wall sealing and Pipe fastening

- Use putty to seal the wall hole.
- Use clamp (pipe fastener) to secure the pipe at specified position.

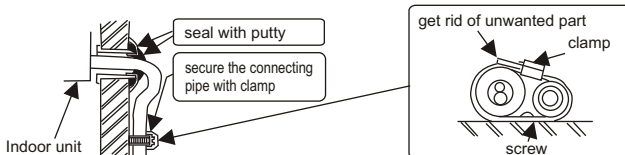

INSTALLATION

Installation diagram of indoor unit and outdoor unit

1 Wiring

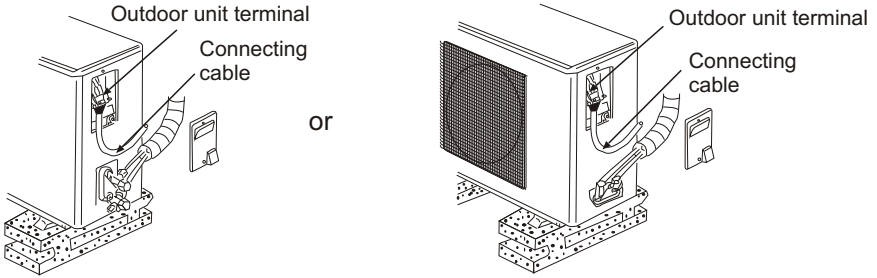

Wiring For Above 6000W Model (Above 21000BTU/h Model)

1 Remove the self-tapping screws (2 pcs) on the maintenance board and take out the maintenance board.

The cable wire can be led from the back hole of the piping hole or ejecting hole.

Please utilize outdoor pipe support when the cable wire is led from the backside.

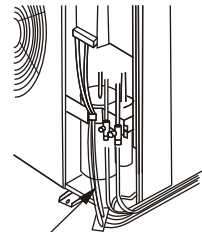
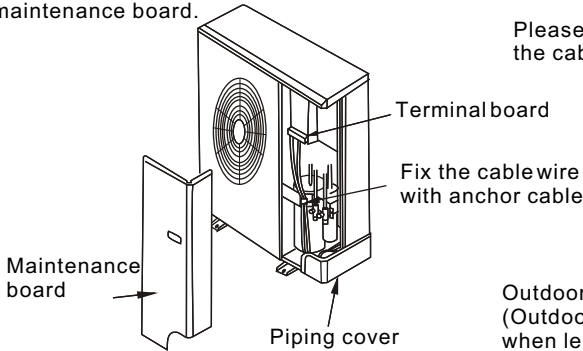

Outdoor pipe support (Outdoor pipe support is not required when leading the cable wire from other places).

2 Loosen the self-tapping screws (2 pcs) on the fixing clip to loosen the fixing clip.

4 Tighten the self-tapping screw on the fixing clip.

3 Loosen the fixing screw of the wire terminal board, pass the power wire and signal wire through the fixing clip. Then firmly fix the power wire and signal wire on the terminal board with the fixing screw. (Earth wire must be connected firmly.)

5 Install the maintenance board. After the pipes and cable wire are installed, please seal the sponge block as per drawing indication.

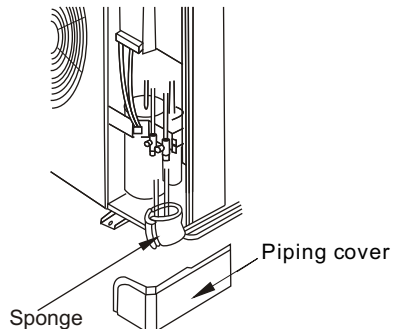
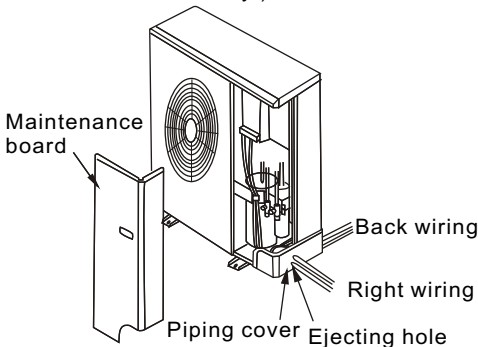

INSTALLATION

Notice:

- If the signal wire has to be bought separately, choose electric wire above 0.75mm^2 .
- If the interconnection cord for power supply has to be replaced, please see the following table for reference.

| MODEL | SPECS (Interconnection cord) |
|---|------------------------------|
| $\leq 2700\text{W}(10000\text{BTU/h})$ | $\geq 1.0\text{mm}^2$ |
| $3000\text{W}(11000\text{BTU/h}) - 4000\text{W}(15000\text{BTU/h})$ | $\geq 1.5\text{mm}^2$ |
| $4500\text{W}(18000\text{BTU/h}) - 8000\text{W}(28000\text{BTU/h})$ | $\geq 2.5\text{mm}^2$ |

WARNING:

- Please take the electric circuit diagram attached to the indoor/outdoor units as major reference while installing.
- The power wire and signal wire between the indoor/outdoor units must be connected one by one as per corresponding number on the wiring terminal board.
- The connecting cables must be clipped together.
- Special cable must be used to connect indoor unit and outdoor unit. It should be ensured that the terminals are not influenced by external force. Poor connection may cause fire.
- The electric box cover must be mounted and secured in position, otherwise fire or electrical shock may occur because of dust or moisture.
- The temperature of refrigerant circuit will be high, please keep the interconnection cable away from the copper tube.
- All the models shall be connected with the mains which has system impedance limitations. While installing the unit, please see the following table for impedance information or consult with the supply authority.

| SERIES | MODEL | IMPEDANCE |
|------------|--------------------|---------------------|
| R22 series | 6800W (24000BTU/h) | $\leq 0.042 \Omega$ |
| | 5100W (18000BTU/h) | $\leq 0.160 \Omega$ |
| | 3500W (12000BTU/h) | $\leq 0.132 \Omega$ |
| | 3200W (10000BTU/h) | $\leq 0.121 \Omega$ |
| | 2500W (9000BTU/h) | $\leq 0.457 \Omega$ |

INSTALLATION

2 Installation of the drain joint(only for heat pump type)

- Insert the outdoor double-channel drain joint in one of the bottom holes of the suitable size then connect drain hose and joint together.

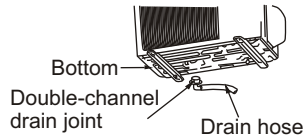

3 Joint of the connecting pipe

- Put some seal oil to cover the joint and the flare.
- Align the centre of joint in line with that of flare and tighten the nut of connecting pipe with wrench. (Adjust the torque by the same method of connecting pipe for indoor unit.)

4 Air exhausting

- Screw down the cap of both gas shut-off valve and liquid shut-off valve as well as the nut of service port.
- Use Allen wrench to turn the valve cork of liquid side at 90° counter-clockwise, and close it after 10 seconds. Use soapy water to check the gas leakage especially at all joint. If there is no gas leakage, please turn the valve cork of liquid side at 90° counter-clockwise again.
- Press the cork of service port at gas shut-off valve, 10 seconds later, when you see foggy gas discharged, that means inner air is exhausted out.
- Use Allen wrench to turn the valve cork of both liquid shut-off valve and gas shut-off valve counter-clockwise until they are completely open and then replace the valve caps and tighten them.

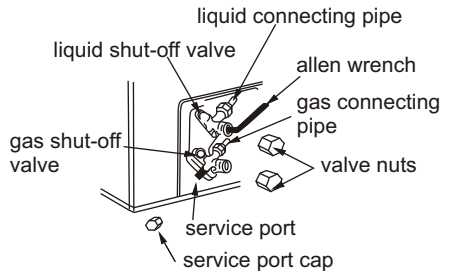

5 Process of flared tube

- Use the pipe cutter to cut off the broken part of flare.
- Remove burrs at the cut of the flare.
- Insert a nut into the connecting pipe and do flaring with specified flaring tools, reamers for example.

Remove burrs at the cut of the flare.

| Outer diameter | A(mm) |
|-----------------|----------|
| 6.35mm (1/4") | 2.0--2.5 |
| 9.52mm (3/8") | 3.0--3.5 |
| 12.7mm (1/2") | 3.5--4.0 |
| 15.88mm(5/8") | 4.0--4.5 |

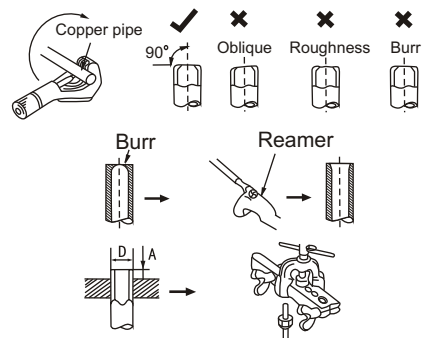

- Check the quality of flaring technique.

INSTALLATION

6 Adding refrigerant

- If the connecting pipe is longer than 7 metres, add refrigerant as needed. (Cool only type) added amount $A=(Lm-7m) \times 15g/m$; (Heat pump type)added amount $A=(Lm-7m) \times 50g/m$. (A: amount of added refrigerant, L: the length of connecting pipe)

| The length of connecting pipe (m) | 7 | 8 | 9 | 10 |
|-----------------------------------|---|----|-----|-----|
| (Cool only type)added amount (g) | 0 | 15 | 30 | 45 |
| (Heat pump type)added amount (g) | 0 | 50 | 100 | 150 |

- Exhaust the air as the above-mentioned method.
- Screw the gas shut-off valve to close, connect charging hose(low pressure) to the service valve and then open gas shut-off valve again.
- Set the unit to cool operation mode.
- Connect the refrigerant bottle to the charging hose and then convert it.
- Fill in liquid refrigerant as the above table.
- Stop operation of the air conditioner.
- Disconnect the manifold gauge after turning off the shut-off valve, and then open gas shut-off valve again.
- Tighten nuts and caps of each valve.

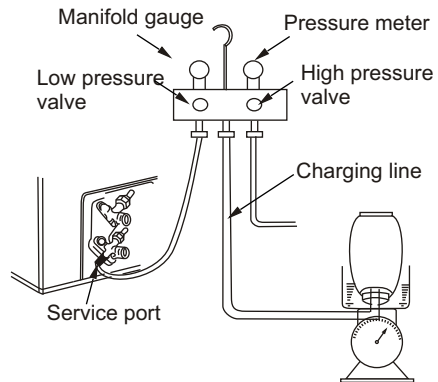

7 Relocation of the air conditioner.

- Refer to this procedure when the unit is relocated.
 1. Carry out the pump down procedure.
 2. Remove the power cord.
 3. Disconnect the assembly cable from the indoor and outdoor units.
 4. Remove the flare nut connecting the indoor unit and the pipe.

At this time, cover the pipe of the indoor unit and the other pipe using a cap or vinyl plug to avoid foreign material entering.
 5. Disconnect the pipe connected to the outdoor unit.
 6. Make sure you do not bend the connection pipes in the middle and store together with the cables.
 7. Move the indoor and outdoor units to a new location.
 8. Remove the mounting plate for the indoor unit and move it to a new location.

INSTALLATION

8 Operation test

- Before test operation, wiring safety inspection must be carried out carefully again.

1. Emergency switch operation: Every press of emergency switch, the air conditioner runs as in the following order:

Cool only type: Cool → Shut off

Heat pump type: Cool → Heat → Shut off

2. Remote controller operation: If the indoor unit sounds like Di, Di when pressing I/O button, that indicates the air conditioner is under the operation of remote controller. After that, press every button to test their functions.

3. Check switch operation: Open the front grille and press the check button. Switch on the power source and then the operation test is activated. If the indicator lamps light up at first and then go out in succession or the LED window of the indoor unit illuminates at first and then goes out, the system is under normal operation. If one of the indicator lamps is flashing at all times, or failure codes are displayed on the LED window of the indoor unit, the system has something wrong and please check malfunction immediately.

BLOCK DIAGRAM

Refrigerant Cycle Block Diagram

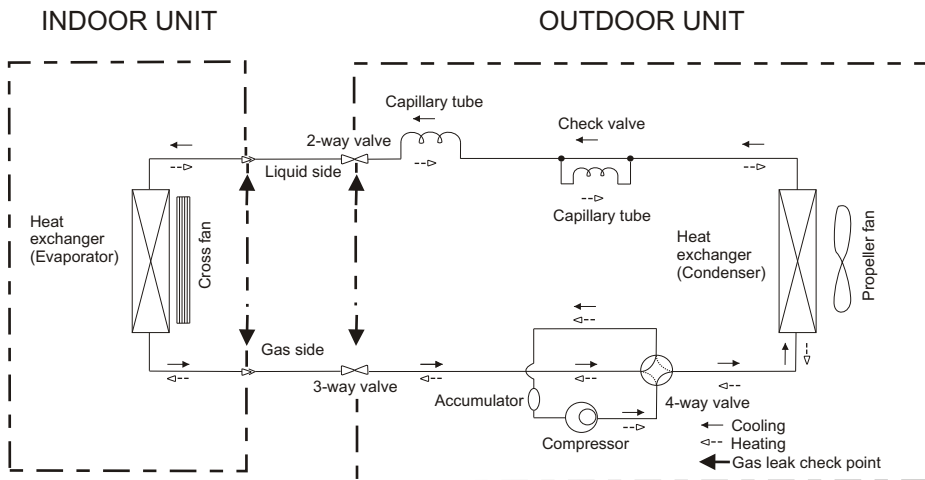

TROUBLE SHOOTING

Items to be checked first

- Is the voltage of the power correct?
The input voltage shall be rating voltage $\pm 10\%$.
The air conditioner may not operate properly if the voltage is out of this range.
- Is the link cable connecting the indoor unit and the outdoor unit linked properly?
Please refer to the "wiring diagram"
Check the terminals if the indoor unit and outdoor unit are properly linked by the same number of cables.
- When a problem occurs due to the contents illustrated in the table below, it is symptom not related to the malfunction of the air conditioner.

| Operation of air conditioner | Explanation |
|---|---|
| In COOL operation mode, the compressor does not operate at a room temperature higher than the setting temperature that the indoor fan should operate. In a HEAT operation mode, the compressor does not operate at a room temperature lower than the setting temperature that indoor fan should operate. | It happens after a delay of 3 minutes when the compressor is reoperated. The same phenomenon occurs when a power is on. As a phenomenon that the compressor is reoperated after a delay of 3 minutes, the indoor fan is adjusted automatically with reference to a temperature of the air blow. |
| Fan speed setting is not allowed in AUTO or DRY mode. | The speed of the indoor fan is set to low in DRY mode. Fan speed of 3 steps is selected automatically in AUTO mode. |
| Compressor stops operation intermittently in DRY mode. | Compressor operation is automatically controlled in DRY mode depending on the room temperature and humidity. |
| Compressor of the outdoor unit is operating although it is turned off in HEAT mode. | When the unit is turned off while de-ice is activated, the compressor continues operation for up to 10 minutes(maximum) until the deice is completed. |
| Timer indicator lamp lights up and the air conditioner does not operate. | Timer is being activated and the unit is in ready mode. The unit operates normally if the timer operation is cancelled. |
| The compressor and indoor fan stop intermittently in HEAT mode. | The compressor and indoor fan stop intermittently if room temperature exceeds a setting temperature in order to protect the compressor from overheated air in HEAT mode. |
| Indoor fan and outdoor fan stop intermittently in HEAT mode. | The compressor operates in a reverse cycle to remove exterior ice in HEAT mode, and indoor fan and outdoor fan do not operate intermittently for within 20% of the total heat operation. |
| The compressor stops intermittently in COOL mode or DRY mode, and fan speed of the indoor unit decreases. | The compressor stops intermittently or the fan speed of the indoor unit decreases to prevent inside/outside air frozen depending on the inside/outside air temperature. |

SELF DIAGNOSIS FUNCTION

Our company provides the end-users with thoughtful services by installing various diagnostic systems to indicate the following irregular performances.

| Check code | Diagnosis of malfunction |
|------------|--------------------------------------|
| FAULT F6 | PG motor faults |
| FAULT F7 | Indoor TEMP sensor faults |
| FAULT F8 | Indoor coil pipe TEMP sensor faults |
| FAULT F9 | Outdoor coil pipe TEMP sensor faults |

| RUN indicator lamp | SLEEP indicator lamp | TIMER indicator lamp | Diagnosis of malfunction |
|--------------------|----------------------|----------------------|--------------------------------------|
| ☆ | ☆ | ☆ | Indoor coil pipe TEMP sensor faults |
| ☆ | ☆ | ● | Indoor TEMP sensor faults |
| ☆ | ☆ | ○ | Outdoor coil pipe TEMP sensor faults |
| ☆ | ● | ☆ | PG motor faults |
| Remark: | ● lamp ON | ○ lamp OFF | ☆ lamp FLASH |

FAULT DIAGNOSIS BY SYMPTOM

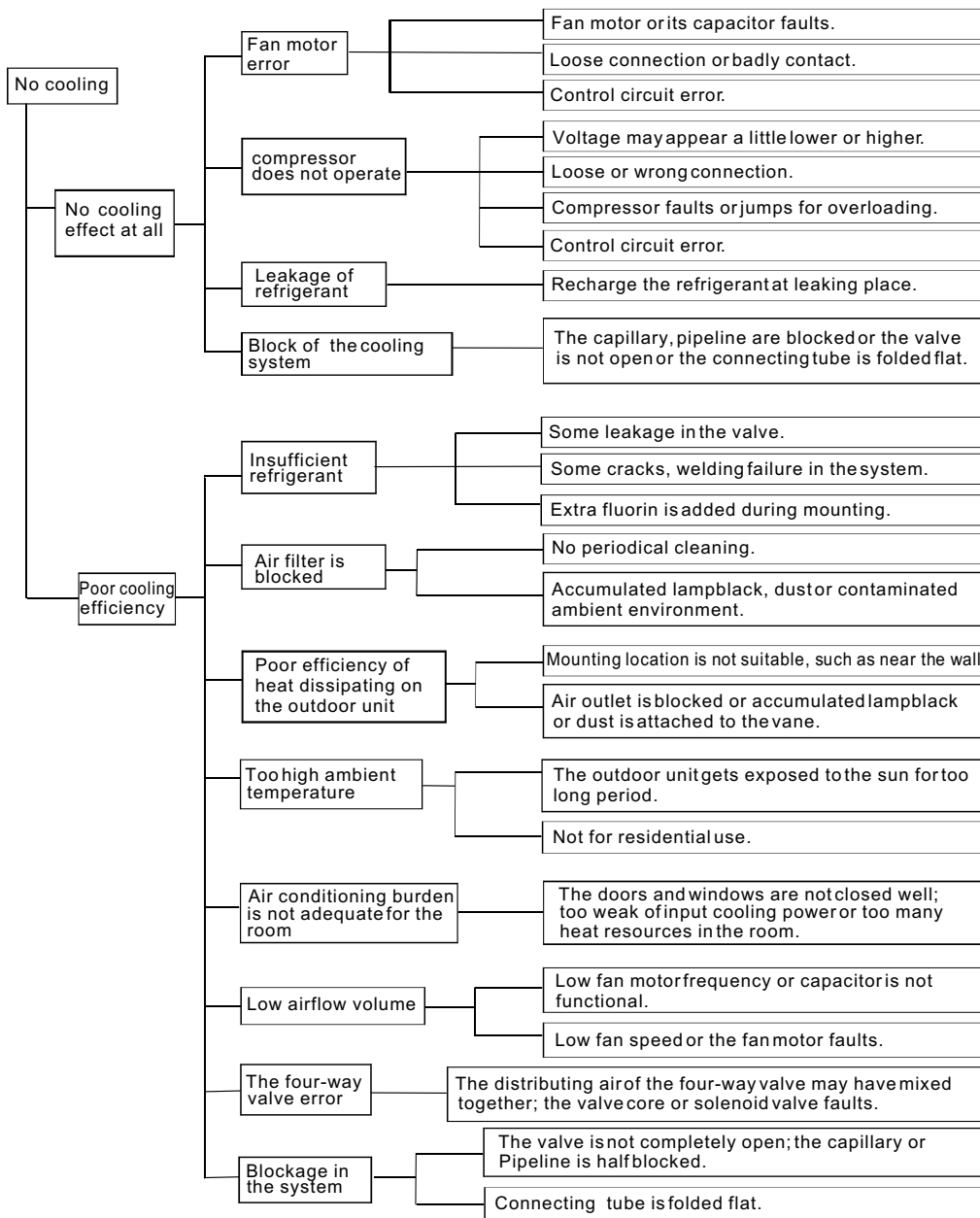

FAULT DIAGNOSIS BY SYMPTOM

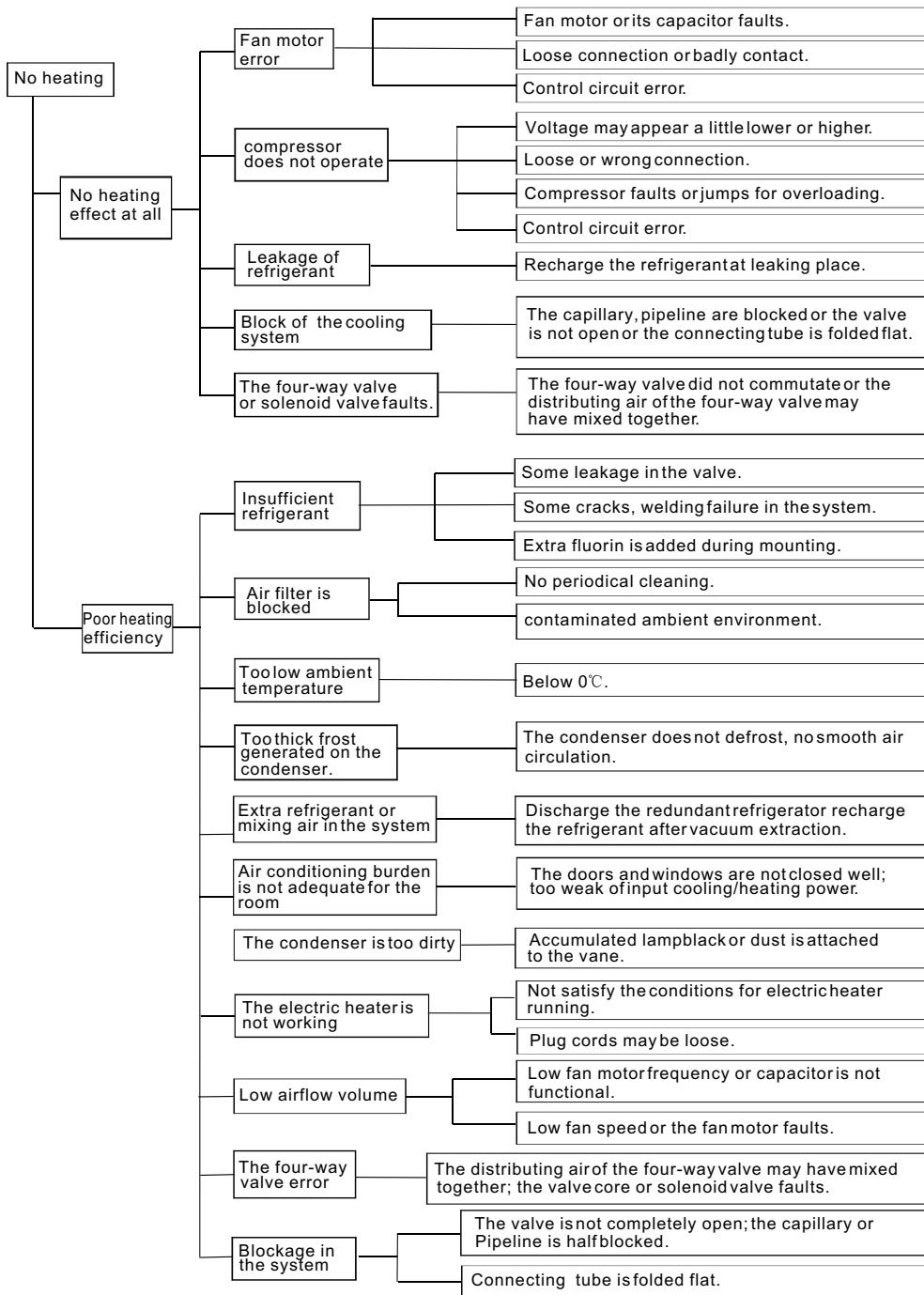

FAULT DIAGNOSIS BY SYMPTOM

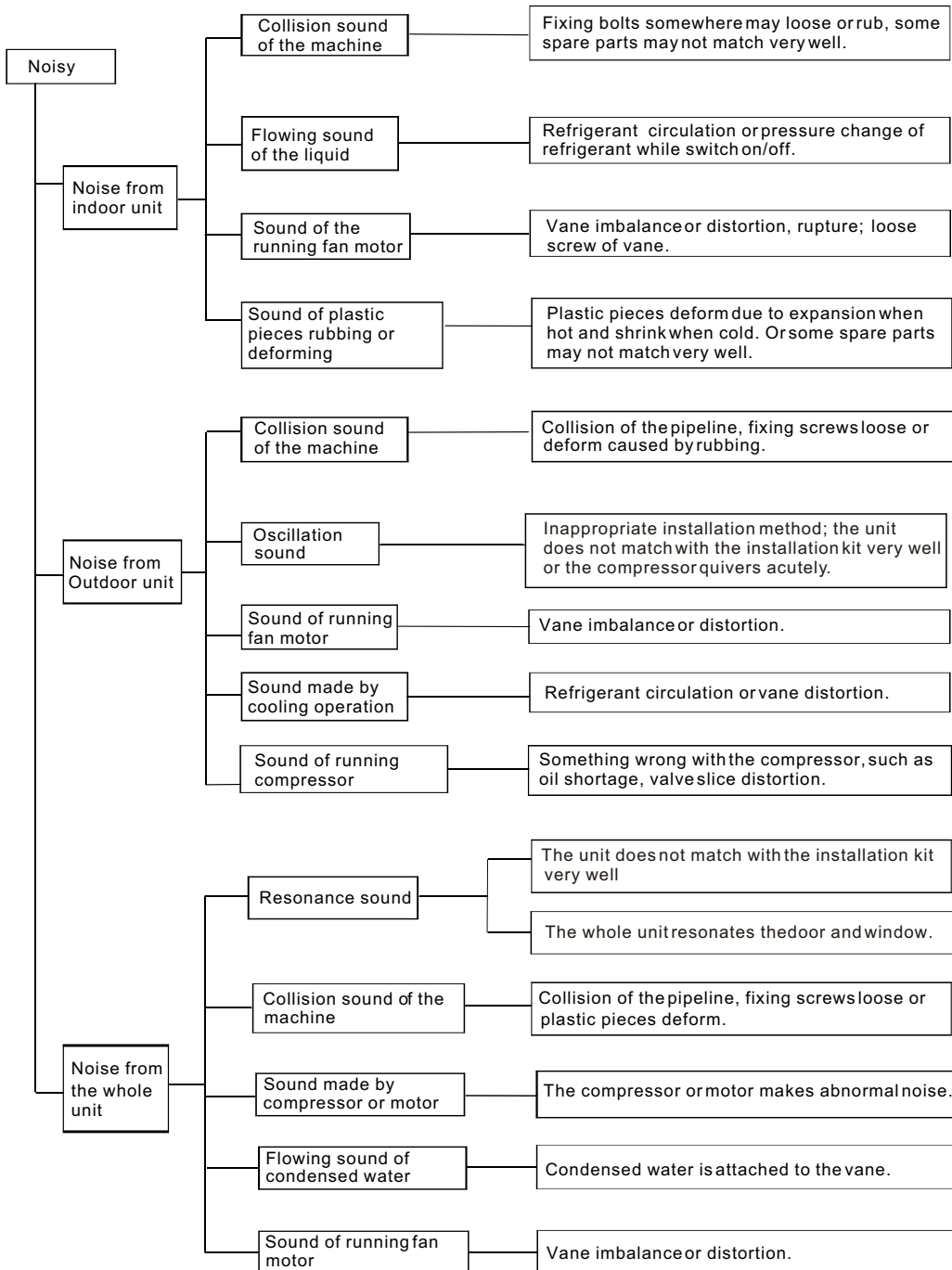

FAULT DIAGNOSIS BY SYMPTOM

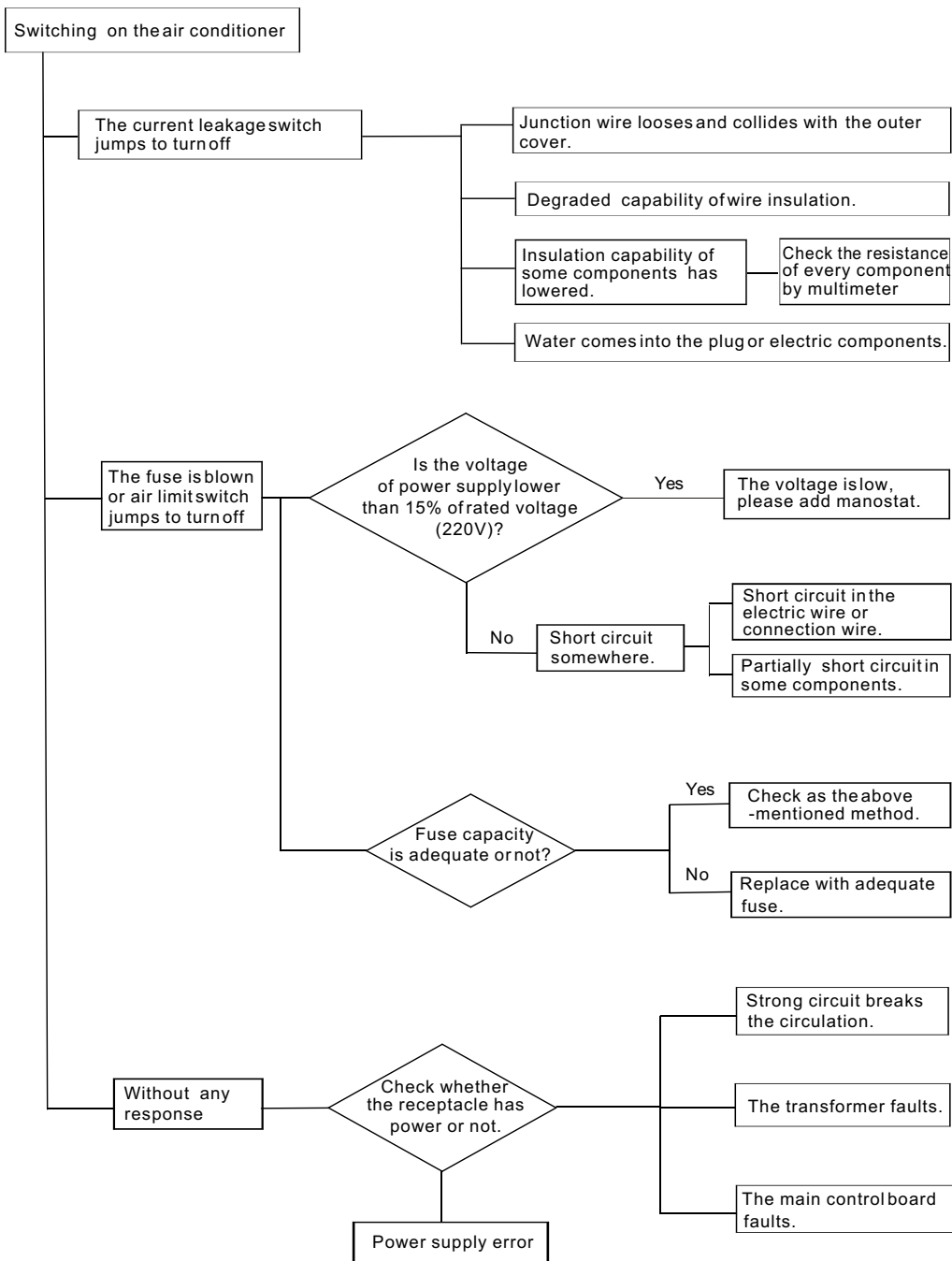

CONTROL SPECIFICATION

1 ABBREVIATION

ST: Setting Temperature
PT: Indoor coil Pipe Temperature
RT: Room Temperature
OT: Outdoor coil pipe temperature
OFAN: Outdoor fan
IFAN: Indoor fan
COMP: Compressor

2 OPERATION OF MAIN BOARD

COOL MODE

- The ST at cool mode is adjustable within 16°C-31°C.
- When $RT \geq ST$, both the compressor and the outdoor fan start;
When $RT < ST - 1^\circ\text{C}$, the compressor stops and 18 seconds later, the outdoor fan will stop. But the indoor fan keeps running at predetermined speed.
- Once turning on the unit while set at cool mode, the indoor fan immediately runs at predetermined speed; if all the conditions meet with the requirement of compressor operation, both the outdoor fan and compressor start running. If not, either the outdoor fan or compressor could start.
- The four-way valve keeps being off all the time at cool mode.

Condensate dew prevention

If the horizontal air flow louver is set at low angle on COOL mode, after a while, it will auto swing to its maximum angel for system protection. 3 minutes later, the horizontal air flow louver will resume to its original position.

Anti-ice function

- When $PT = 2^\circ\text{C}$, the compressor does not stop and indoor fan runs at high speed.
- When $PT \leq -1^\circ\text{C}$ for 1 minute, the compressor and outdoor fan stop and indoor fan runs at high speed.
- When $PT \geq 8^\circ\text{C}$ for 5 minutes, anti-ice protection deactivates, both the compressor and the outdoor fan start operation.

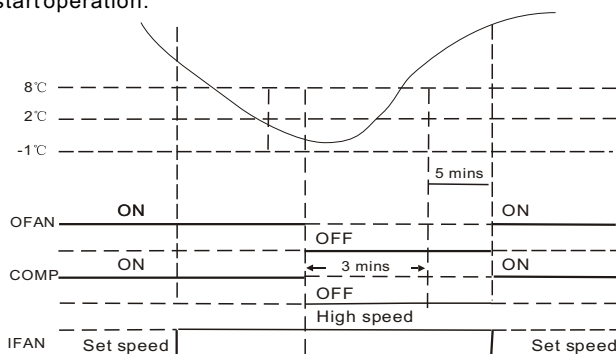

CONTROL SPECIFICATION

HEAT MODE

- If the air conditioner is off and then turned on while set at COOL, HEAT or DRY mode, it will take approximately 3 minutes for the compressor to start.
- The ST at heat mode is adjustable within 16°C-31°C.
- When $RT \geq ST$, the compressor stops; when $RT < ST - 1^\circ\text{C}$, the compressor starts.
- Once turning on the unit while set at heat mode, if all the conditions meet with the requirement of compressor operation, the four-way valve gets charged and 8 seconds later, the compressor and outdoor fan start running.

Strong-wing prevention :

- A. $PT < 27$, the indoor fan stops running, the swing louver cannot be controlled by the remote controller.
- B. $34 > PT \geq 27$, the indoor fan runs at low speed, the sweep louver erects.
- C. $PT \geq 34$, the indoor fan and the swing louver can be controlled normally.

Heat overload protection:

- For R22 series, when $PT \geq 50^\circ\text{C}$, the outdoor fan stops; when $PT \leq 47^\circ\text{C}$, the outdoor fan starts; when $PT \geq 63^\circ\text{C}$, the compressor stops.

Deice control:

- Conditions for activating deice:
 - a. The working hours of compressor accumulates to be 40 minutes.
 - b. When $OT \leq -4^\circ\text{C}$ for 1 minute.
- Conditions for terminating deice:
 - a. When $OT \geq 15^\circ\text{C}$ for 1 minute.
 - b. Over 10 minutes of deicing operation.

Electric-heat control:

- Conditions for initiating electric-heat function:
 - a. $RT \leq 23^\circ\text{C}$; b. $RT + 3^\circ\text{C} \leq ST$; c. The indoor fan runs;
 - d. Turn on the electric-heat key; e. $PT < 50^\circ\text{C}$
- Conditions for terminating electric-heat function:
 - a. $PT \geq 50^\circ\text{C}$; b. $RT \geq 26^\circ\text{C}$; c. The indoor fan stops running;
 - d. Turn off the electric-heat key; e. Mode change.
- Conditions for terminating electric-heat function:
 - a. $PT \geq 50^\circ\text{C}$; b. $RT \geq 26^\circ\text{C}$; c. The indoor fan stops running;
 - d. Turn off the electric-heat key; e. Mode change.

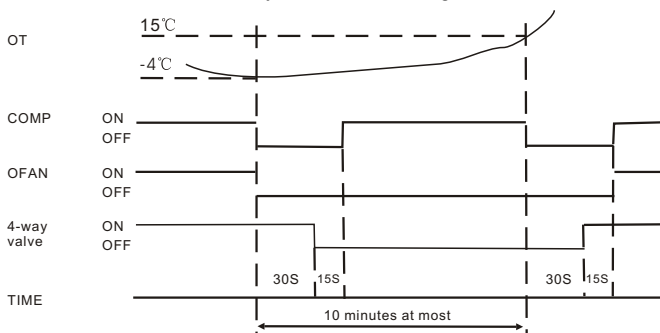

CONTROL SPECIFICATION

■ DRY MODE

- In this mode, the air conditioner automatically sets the room temperature and this temperature is uncontrollable by remote controller. The initial $ST = RT - 2^{\circ}C$.
- Control during dry mode:
 - a. When $RT < 15^{\circ}C$, dry mode is not available; when $RT \geq 15^{\circ}C$, the compressor intermittently runs under the influence of TS and RT .
 - b. When $RT \geq 23^{\circ}C$, if $RT \geq ST$, the compressor runs intermittently as this:
Run for 8 minutes \longrightarrow Stop for 3 minutes



If $RT < ST$, the compressor runs intermittently as this:

Stop for 4 minutes \longrightarrow Run for 1 minute



c. When $RT < 23^{\circ}C$, if $RT \geq ST$, the compressor runs intermittently as this:

Run for 2 minutes \longrightarrow Stop for 3 minutes



If $RT < ST$, the compressor runs intermittently as this:

Stop for 4 minutes \longrightarrow Run for 1 minute



d. In this mode, the indoor fan keeps running at low speed with the same pace as the compressor, and this speed can not be controlled by remote controller.

■ AUTO MODE

- In this mode, the air conditioner can automatically adjust the room temperature to decide the most suitable temperature. At the start of operation, the unit will automatically select the operation mode according to the room temperature. The following table shows the conditions which are set at start up.

| Room Temperature (RT) | Cool only type | | Heat pump type | |
|-------------------------------------|----------------|-----------------------------|----------------|-----------------------------|
| | Mode | Initial Setting Temperature | Mode | Initial Setting Temperature |
| $RT \geq 26^{\circ}C$ | Cool | $24^{\circ}C$ | Cool | $24^{\circ}C$ |
| $26^{\circ}C > RT \geq 25^{\circ}C$ | | $RT - 2$ | | $RT - 2$ |
| $25^{\circ}C > RT \geq 23^{\circ}C$ | Dry | $RT - 2$ | Dry | $RT - 2$ |
| $RT < 23^{\circ}C$ | | $21^{\circ}C$ | | Heat |

- Auto mode entering
 - a. Once some operation mode is determined, it can not be changed even if the RT has altered.
 - b. You can change the operation mode by remote controller.
- If restart within 2 hours, the unit will resume the same operation mode as before.
If restart after 2 hours, the unit will select the operation mode according to the initial room temperature.
- At auto mode the ST can only be set $+ or - 2^{\circ}C$ of the RT .

CONTROL SPECIFICATION

■ FAN MODE

In this mode, the outdoor unit does not operate. The indoor fan alone operates.

Press UP & DOWN SWING button or LEFT & RIGHT SWING button to change air flow direction.

Press FAN SPEED button to change the fan speed of indoor unit.

■ LIGHT-WAVE MODE (only applied to light-wave series)

Every press of LIGHT-WAVE button, the air conditioner will cycle in the order of enter/quit light-wave mode. Once entering the light-wave mode, the light-wave icon will light up on display panel of the indoor unit and the air conditioner will judge whether to connect the light-wave tube by ambient temperature.

■ TURBO function (only applied to turbo series)

This function will make the air conditioner heat or cool quickly and during this period, the noise of the air conditioner will increase. Turbo function can be only started up in heat or cool mode (turbo heating or turbo cooling) otherwise, it can not be started up. When the air conditioner is in cool or heat mode, press turbo button to initiate turbo function, the remote controller displays “TURBO” and the icon of fan speed is “”, meanwhile the air conditioner cannot be controlled by the remote controller. Press turbo button again or start up sleep mode or transit modes to exit turbo function. After exiting turbo function the fan runs at low speed.

■ FRESH AIR function (only applied to fresh air series)

When the air conditioner is on, press fresh air button to initiate or stop fresh air function. While this function is initiated the remote controller displays “FRESH AIR”, meanwhile the fan starts to run, the letter “FRESH AIR” extinguishes and the fan stops if fresh air function stops.

■ CLEAN function (only applied to clean series)

When the air conditioner is on, press CLEAN/PLASMA button for 3 seconds to initiate or stop clean function. While this function is initiated the remote controller displays “CLEAN” and it will extinguish if clean function stops. Please note that after clean function starts up, the evaporator will only clean automatically on the condition that the air conditioner is turned off normally. Moreover, after the evaporator is checked dirty by the system, the LED of indoor unit will display “CLEAN” to remind you of starting up the clean function.

■ AIR QUALITY CHECKING function (only applied to air quality checking series)

When the air conditioner is on, air quality checking function starts up automatically, at the same time the air quality indicator light on the indoor unit will flash once, which shows that the air conditioner starts up air quality checking function. After the air quality checking function is initiated, if the air quality is good the indicator light extinguishes; if the air quality is bad the indicator light will flash 5 times then lighten. Air quality is showed through the lightness of the indicator light, the lighter the indicator the worse the air quality. When the indicator light is lighten, fresh air function is supposed to be started up. After the air is renewed, the system will stop or continue fresh air function according to the air quality. You can also stop fresh air function as you like. When the air conditioner is turned off, the indicator light will flash once to show the air quality checking function is in gear. And every time starting up inoizer, aux-heat, light-wave, plasma, clean and turbo function the indicator light will flash once.

CONTROL SPECIFICATION

■ SLEEP mode

Normal sleep

When the air conditioner is in cooling and dry mode, the indoor fan runs at low speed. After one hour of operation the set temperature will increase by 1°C. One hour later, the set temperature will increase by 1°C once more. The unit will then continue operating at 2°C above the set temperature.

When the air conditioner is in heating mode, the indoor fan runs at low speed. After one hour of operation the set temperature will decrease by 2°C. One hour later, the set temperature will decrease by 2°C once more. The unit will then continue operating at 4°C below the set temperature.

Sleep mode 1 1

When the air conditioner is in cooling and dry mode and $23^{\circ}\text{C} \geq \text{st} \geq 16^{\circ}\text{C}$, during the 3 hours after sleep mode 1 start up, the set temperature will increase by 1°C every hour. The unit will continue operating at 3°C above the set temperature. 8 hours later, the set temperature will decrease 2°C. The unit will then continue operating at this temperature.

When $24^{\circ}\text{C} \geq \text{st} \geq 27^{\circ}\text{C}$, during the 2 hours after sleep mode 1 start up, the set temperature will increase by 1°C every hour. The unit will continue operating at 2°C above the set temperature. 8 hours later, the set temperature will decrease 2°C, the unit will continue operating at this temperature.

When $28^{\circ}\text{C} \geq \text{st} \geq 31^{\circ}\text{C}$, the unit will operate at the set temperature all along.

When the air conditioner is in heat mode and $18^{\circ}\text{C} \geq \text{st} \geq 16^{\circ}\text{C}$, the unit will operate at the set temperature all along.

When $19^{\circ}\text{C} \geq \text{st} \geq 25^{\circ}\text{C}$, during the 2 hours after sleep mode 1 start up, the set temperature will decrease by 1°C every hour. The unit will continue operating at 2°C below the set temperature. 8 hours later, the set temperature will increase 2°C, the unit will continue operating at this temperature.

When $26^{\circ}\text{C} \geq \text{st} \geq 31^{\circ}\text{C}$, during the 3 hours after sleep mode 1 start up, the set temperature will decrease by 1°C every hour. The unit will continue operating at 3°C below the set temperature. 8 hours later, the set temperature will increase 2°C. The unit will then continue operating at this temperature.

Sleep mode 2 2

When the air conditioner is in cooling and dry mode and $23^{\circ}\text{C} \geq \text{st} \geq 16^{\circ}\text{C}$, during the 3 hours after sleep mode 2 start up, the set temperature will increase by 1°C every hour. The unit will continue operating at 3°C above the set temperature. 7 hours later, the set temperature will decrease 1°C. The unit will then continue operating at this temperature.

When $24^{\circ}\text{C} \geq \text{st} \geq 27^{\circ}\text{C}$, during the 2 hours after sleep mode 2 start up, the set temperature will increase by 1°C every hour. The unit will continue operating at 2°C above the set temperature. 7 hours later, the set temperature will decrease 1°C, the unit will continue operating at this temperature.

When $28^{\circ}\text{C} \geq \text{st} \geq 31^{\circ}\text{C}$, the unit will operate at the set temperature all along.

When the air conditioner is in heat mode and $18^{\circ}\text{C} \geq \text{st} \geq 16^{\circ}\text{C}$, the unit will operate at the set temperature all along.

When $19^{\circ}\text{C} \geq \text{st} \geq 25^{\circ}\text{C}$, during the 2 hours after sleep mode 2 start up, the set temperature will decrease by 1°C every hour. The unit will continue operating at 2°C below the set temperature. 7 hours later, the set temperature will increase 1°C, the unit will continue operating at this temperature.

When $26^{\circ}\text{C} \geq \text{st} \geq 31^{\circ}\text{C}$, during the 3 hours after sleep mode 2 start up, the set temperature will decrease by 1°C every hour. The unit will continue operating at 3°C below the set temperature. 7 hours later, the set temperature will increase 1°C. The unit will then continue operating at this temperature.

CONTROL SPECIFICATION

Sleep mode 3 3

When the air conditioner is in cooling and dry mode and $23\text{C} \geq \text{st} \geq 16\text{C}$, during the 3 hours after sleep mode 3 start up, the set temperature will increase by 1C every hour. The unit will continue operating at 3C above the set temperature.

When $24\text{C} \geq \text{st} \geq 27\text{C}$, during the 2 hours after sleep mode 3 start up, the set temperature will increase by 1C every hour. The unit will continue operating at 2C above the set temperature.

When $28\text{C} \geq \text{st} \geq 31\text{C}$, the unit will operate at the set temperature all along.

When the air conditioner is in heat mode and $18\text{C} \geq \text{st} \geq 16\text{C}$, the unit will operate at the set temperature all along.

When $19\text{C} \geq \text{st} \geq 25\text{C}$, during the 2 hours after sleep mode 3 start up, the set temperature will decrease by 1C every hour. The unit will continue operating at 2C below the set temperature.

When $26\text{C} \geq \text{st} \geq 31\text{C}$, during the 3 hours after sleep mode 3 start up, the set temperature will decrease by 1C every hour. The unit will continue operating at 3C below the set temperature.

■ PLASMA function (only applied to plasma series)

When the air conditioner is on, press CLEAN/PLASMA button to start or stop plasma function.

The LED of the remote controller displays “” while it is initiated and extinguishes while it stops.

■ INOIZER function (only applied to inoizer series)

Press inoizer button to start or stop inoizer function when the air conditioner is on or set timer.





The LED of the remote controller displays “” while it is initiated and extinguishes while it stops.

This function can only be stopped by pressing inoizer button or turning off the air conditioner.

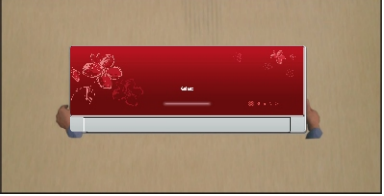
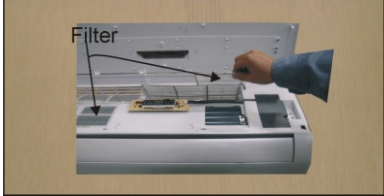

TO DISASSEMBLE MECHANICAL PARTS

Stop operation of the air conditioner and remove the power cord before repairing the unit.
The following pictures taking P1 as an example are presented just for the purpose of illustration.

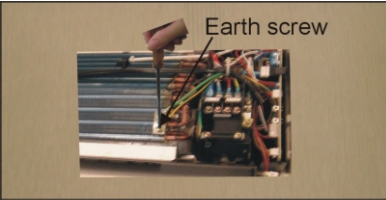
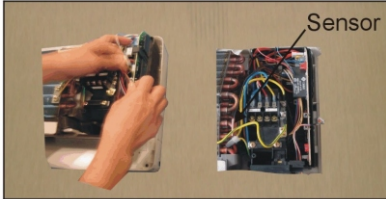
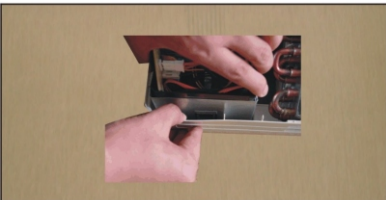
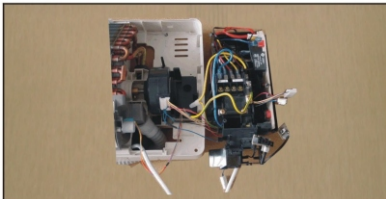

Indoor unit

| No | Parts | Procedure | Remark |
|----|--------------|--|---|
| 1 | Front grille | <p>1. Stop the air conditioner operation and block the main power.</p> <p>2. Contract the second finger to the left, and right handle and pull to open the inlet grille.</p> <p>3. Draw away signal line.</p> <p>4. Take the left and right filter out.</p> <p>5. Loosen two fixing screw of front grille.</p> <p>6. Put hands at the two ruts of the body, then pull the front panel out.</p> |      |

TO DISASSEMBLE MECHANICAL PARTS

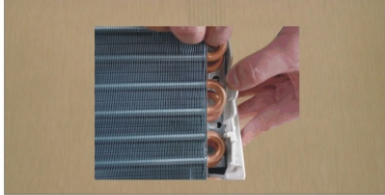

| No | Parts | Procedure | Remark |
|----|------------------|---|---|
| 2 | Electrical parts | <p>1. Loosen the earth screw in evaporator.</p> <p>2. Loosen the stepping motor line, and pull softly the indoor pipe temperature sensor out from the pipe casing.</p> <p>3. Push the hook outside to take the electrical box out easily.</p> <p>4. Separate the electrical box from the indoor unit.</p> |     |
| 3 | Ass'y tray drain | <p>1. Push the left and right hooks to make the ass'y pulled out.</p> |  |

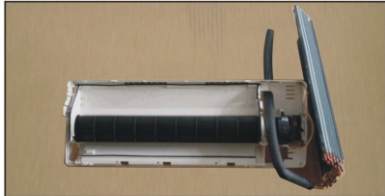
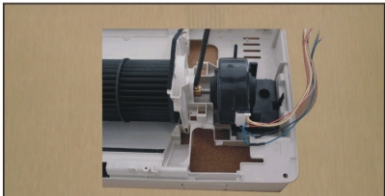
TO DISASSEMBLE MECHANICAL PARTS

| No | Parts | Procedure | Remark |
|----|-------------------------|---|--|
| | | 2. Separate the ass'y tray drain from the body. |  |
| 4 | Evaporator | <p>1. Push the left hook and separate the left part out of evaporator.</p> <p>2. Push the right hook and separate the right part out of evaporator.</p> <p>3. Separate the evaporator from the indoor unit.</p> |    |
| 5 | Fan motor and cross fan | 1. Separate the fan motor from the fan. |  |

TO DISASSEMBLE MECHANICAL PARTS

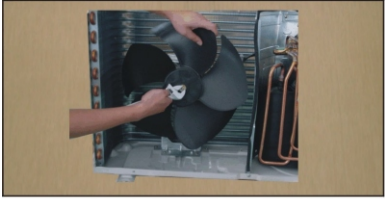
Outdoor unit

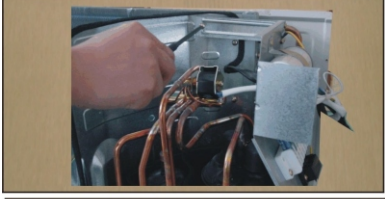
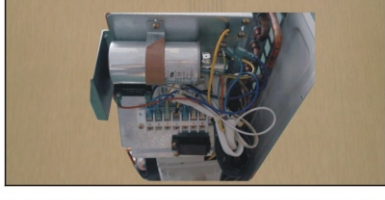
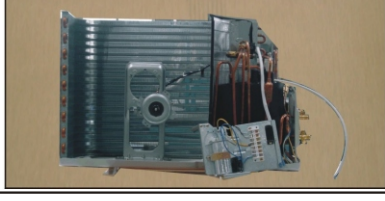
| No | Parts | Procedure | Remark |
|----|---------------------------|--|---|
| 1 | Cabinet | <ol style="list-style-type: none">1. Turn off the unit and remove the power cable.2. Remove the upper cabinet, the front cabinet and back cabinet. |  |
| 2 | Fan motor & propeller fan | <ol style="list-style-type: none">1. Remove the nut flange. (Turn to the right to remove as it is a left turned screw)2. Separate the propeller fan from the fan motor.3. Loosen the fixed screw of the fan motor, separate the fan motor from the outdoor unit. |   |
| 3 | Ass'y control out | <ol style="list-style-type: none">1. Loosen the fixing screw of the base-electrical control.2. Separate the connector.3. Separate the ass'y control out from the outdoor unit. |    |

Exploded Views and Parts List

Indoor unit

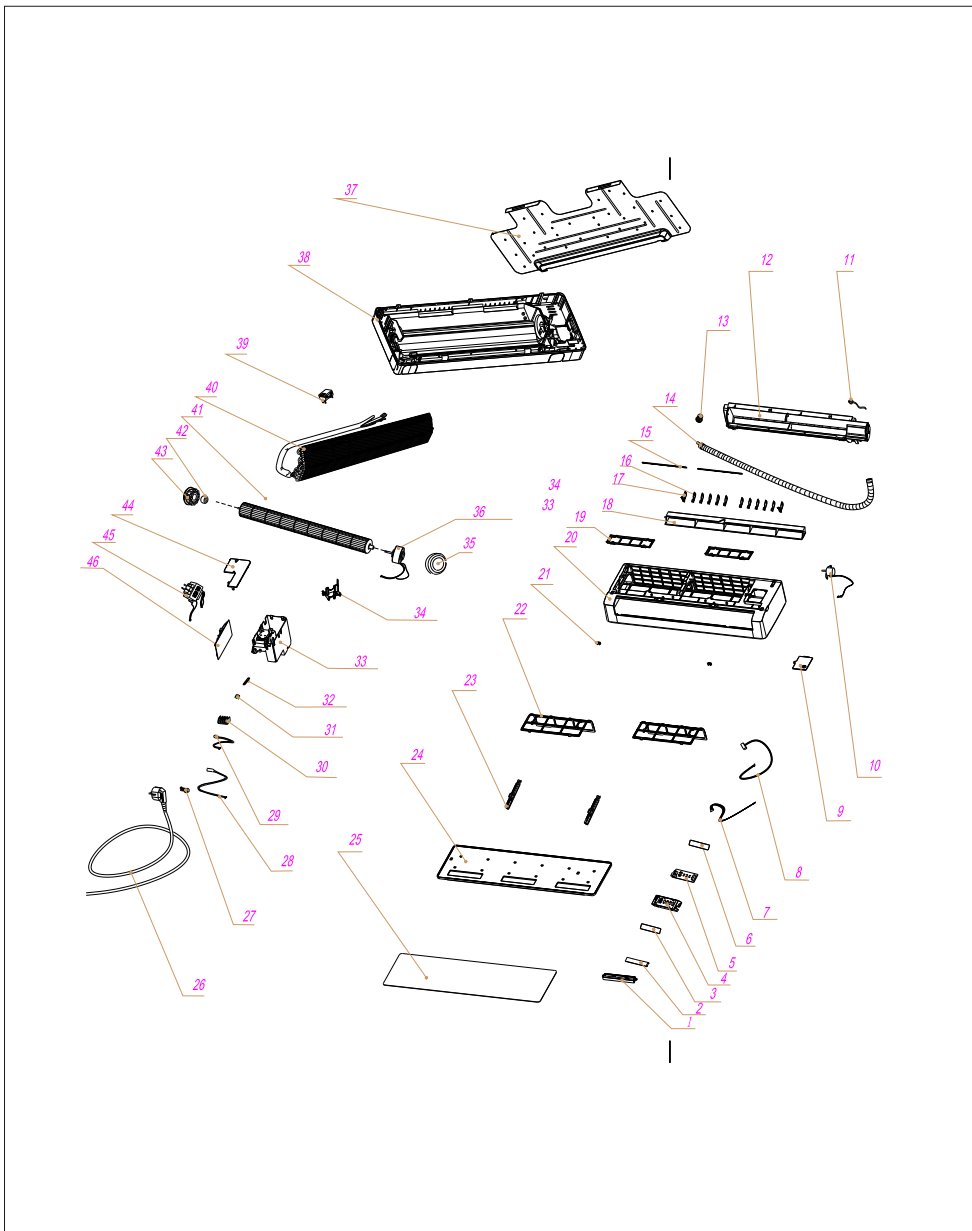

Exploded Views and Parts List

Indoor unit

| No. | English Part Name | Quantity | No. | English Part Name | Quantity |
|-----|--|----------|-----|--|----------|
| 1 | Electrical control box with air sensitive display (optional) | 1 | 28 | Temperature sensor | 1 |
| 2 | Air sensitive display panel(optional) | 1 | 29 | Temperature sensor | 1 |
| 3 | Air sensitive display piece(optional) | 1 | 30 | Terminal block | 1 |
| 4 | Display electrical control box | 1 | 31 | Spring piece | 2 |
| 5 | LED | 1 | 32 | Grounded terminal | 1 |
| 6 | Display piece | 1 | 33 | Electrical control box for P1 | 1 |
| 7 | Connecting wire for LED | 1 | 34 | Electrical supporter | 1 |
| 8 | Connecting wire | 1 | 35 | Rubber shock absorption base | 1 |
| 9 | Cover for front panel | 1 | 36 | Fan motor | 1 |
| 10 | Stepping motor | 1 | 37 | Mounting plate | 1 |
| 11 | Ionizer(optional) | 1 | 38 | Bottom enclosure | 1 |
| 12 | Water collecting tray for P1 | 1 | 39 | Air sensitive detecting assembly(optional) | 1 |
| 13 | Drain cap | 1 | 40 | Evaporator | 1 |
| 14 | Drain hose | 1 | 41 | Indoor unit fan | 1 |
| 15 | Connecting pole | 2 | 42 | Oil bearing | 1 |
| 16 | Air leading vane | 10 | 43 | Rubber bear support | 1 |
| 17 | Air leading plectrum | 2 | 44 | Cover of electrical control box for P1 | 1 |
| 18 | Swing louver for P1 | 1 | 45 | Transformer | 1 |
| 19 | Air filter supporter | 2 | 46 | Main control board | 1 |
| 20 | P1 front panel | 1 | | | |
| 21 | Screw cover for B3 | 2 | | | |
| 22 | Air filter | 2 | | | |
| 23 | Supporter for front panel | 2 | | | |
| 24 | Front panel for P series(optional) | 1 | | | |
| 25 | Decorating board for front panel of P series | 1 | | | |
| 26 | Power supply cord | 1 | | | |
| 27 | Power supply cord clip | 1 | | | |

Exploded Views and Parts List

Outdoor unit
AUS-07C53F010Px
AUS-09C53F010Px

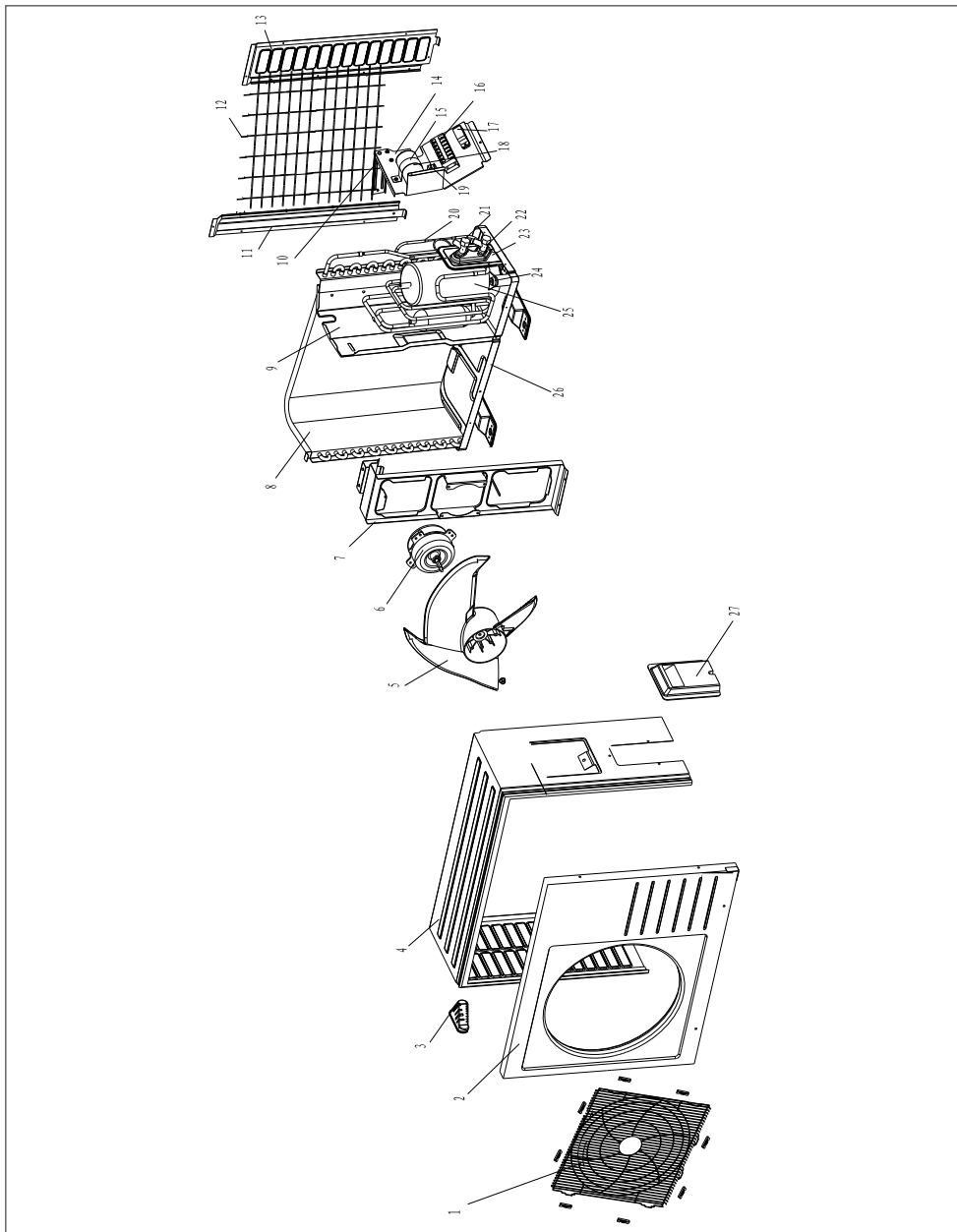

Exploded Views and Parts List

AUS-07C53F010Px

Outdoor unit AUS-09C53F010Px

| No. | English Part Name | Quantity | No. | English Part Name | Quantity |
|-----|------------------------------------|----------|-----|-------------------|----------|
| 1 | Air outlet grille | 1 | | | |
| 2 | Front panel | 1 | | | |
| 3 | Left handle | 1 | | | |
| 4 | Top cover | 1 | | | |
| 5 | Outdoor unit fan | 1 | | | |
| 6 | Outdoor fan motor | 1 | | | |
| 7 | Outdoor fan motor supporter | 1 | | | |
| 8 | Condenser | 1 | | | |
| 9 | Partition | 1 | | | |
| 10 | Electrical install board supporter | 1 | | | |
| 11 | Left back side plate | 1 | | | |
| 12 | Back cover | 1 | | | |
| 13 | right back side plate | 1 | | | |
| 14 | Electrical install board | 1 | | | |
| 15 | Capacitor fixing clip | 1 | | | |
| 16 | Outdoor unit terminal block | 1 | | | |
| 17 | power supply cord clip | 1 | | | |
| 18 | capacitor for Compressor | 1 | | | |
| 19 | Fan motor capacitor | 1 | | | |
| 20 | Capillary assembly | 1 | | | |
| 21 | High pressure valve | 1 | | | |
| 22 | Low pressure valve | 1 | | | |
| 23 | valve board | 1 | | | |
| 24 | Compressor screw | 3 | | | |
| 25 | Compressor | 1 | | | |
| 26 | Bottom board | 1 | | | |
| 27 | Right handle | 1 | | | |

Exploded Views and Parts List

AUS-09H53F010Px

Outdoor unit AUS-07H53F010Px

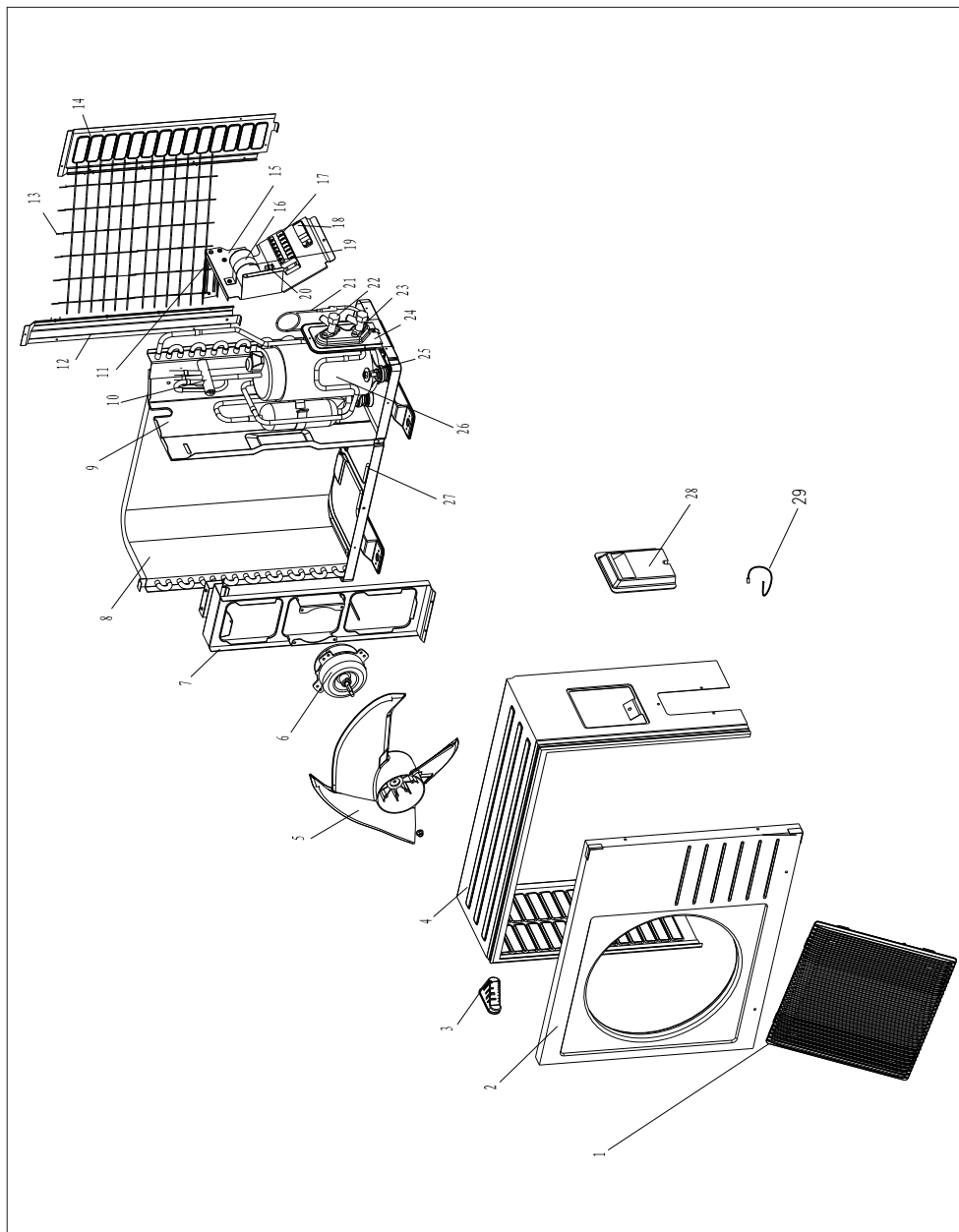

Exploded Views and Parts List

AUS-09H53F010Px

Outdoor unit

AUS-07H53F010Px

| Number | Name | Quantity | Number | Name | Quantity |
|--------|------------------------------------|----------|--------|---------------------|----------|
| 1 | Air outlet grille | 1 | 28 | Right handle | 1 |
| 2 | Front panel | 1 | 29 | Outdoor pipe sensor | 1 |
| 3 | Left handle | 1 | | | |
| 4 | Top cover | 1 | | | |
| 5 | Outdoor unit fan | 1 | | | |
| 6 | Outdoor fan motor | 1 | | | |
| 7 | Outdoor fan motor supporter | 1 | | | |
| 8 | Condenser | 1 | | | |
| 9 | Partition | 1 | | | |
| 10 | Four way valve | 1 | | | |
| 11 | Electrical install board supporter | 1 | | | |
| 12 | Left back side plate | 1 | | | |
| 13 | Back cover | 1 | | | |
| 14 | Right back side plate | 1 | | | |
| 15 | Electrical install board | 1 | | | |
| 16 | Capacitor fixing clip | 1 | | | |
| 17 | Outdoor unit terminal block | 1 | | | |
| 18 | Power supply cord clip | 1 | | | |
| 19 | Capacitor for Compressor | 1 | | | |
| 20 | Fan motor capacitor | 1 | | | |
| 21 | Capillary assembly | 1 | | | |
| 22 | High pressure valve | 1 | | | |
| 23 | Low pressure valve | 1 | | | |
| 24 | Valve board | 1 | | | |
| 25 | Compressor screw | 3 | | | |
| 26 | Compressor | 1 | | | |
| 27 | Bottom board | 1 | | | |

Exploded Views and Parts List

Outdoor unit AUS-12H53F110Px

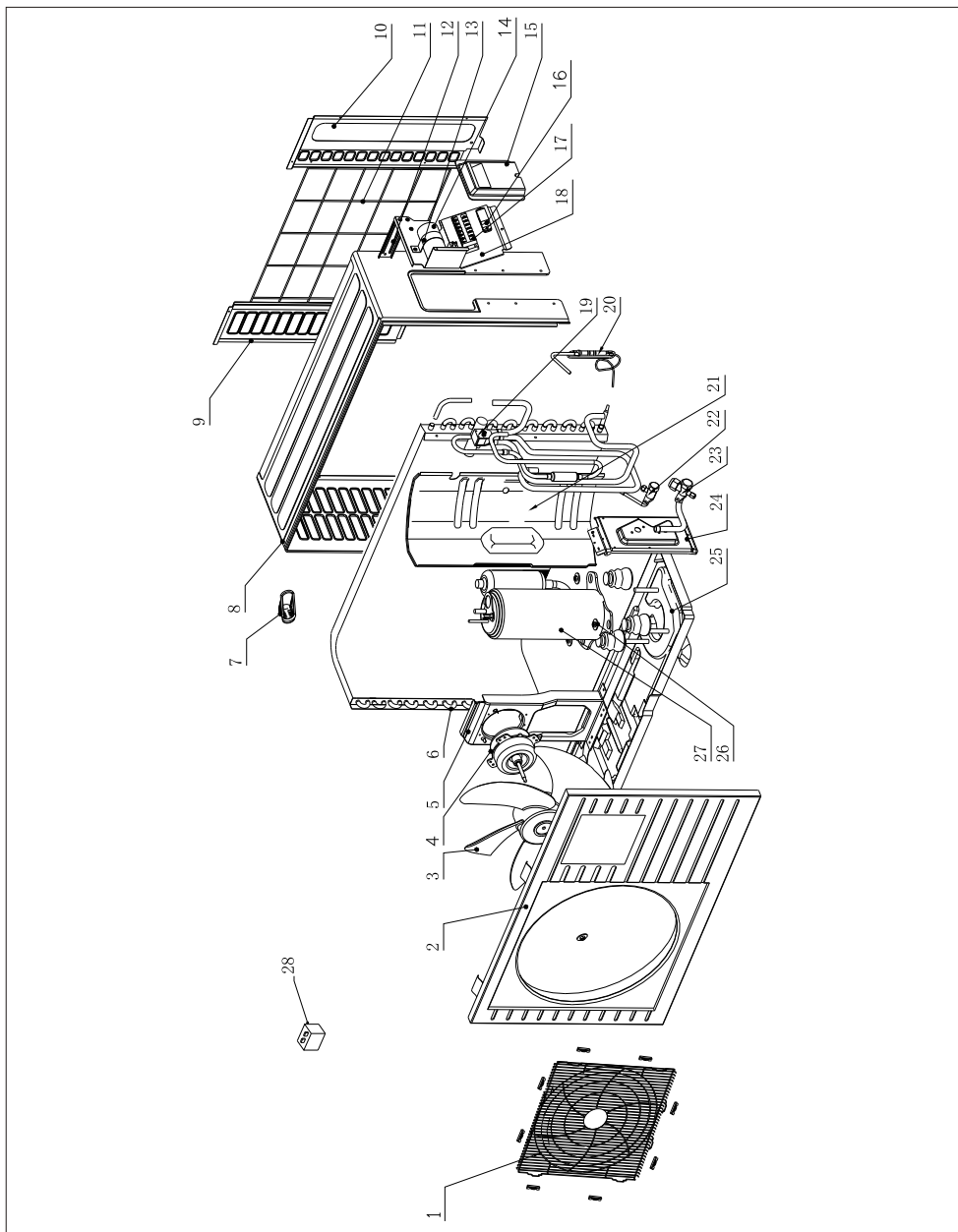

Exploded Views and Parts List

Outdoor unit AUS-12H53F110Px

| No. | English Part Name | Quantity | No. | English Part Name | Quantity |
|-----|------------------------------------|----------|-----|---------------------|----------|
| 1 | Air outlet grille | 1 | 28 | Fan motor capacitor | 1 |
| 2 | Front panel | 1 | | | |
| 3 | Outdoor unit fan | 1 | | | |
| 4 | Outdoor fan motor | 1 | | | |
| 5 | Outdoor fan motor supporter | 1 | | | |
| 6 | Condenser | 1 | | | |
| 7 | Left handle | 1 | | | |
| 8 | Top cover | 1 | | | |
| 9 | Left back side plate | 1 | | | |
| 10 | Right back side plate | 1 | | | |
| 11 | Back cover | 1 | | | |
| 12 | Electrical install board supporter | 1 | | | |
| 13 | Capacitor fixing clip | 1 | | | |
| 14 | Capacitor for compressor | 1 | | | |
| 15 | Right handle | 1 | | | |
| 16 | power supply cord clip | 1 | | | |
| 17 | Outdoor unit terminal block | 1 | | | |
| 18 | Electrical install board | 1 | | | |
| 19 | Four way valve | 1 | | | |
| 20 | Capillary assembly | 1 | | | |
| 21 | Partition | 1 | | | |
| 22 | High pressure valve | 1 | | | |
| 23 | Low pressure valve | 1 | | | |
| 24 | Valve board | 1 | | | |
| 25 | Bottom board | 1 | | | |
| 26 | Compressor screw | 3 | | | |
| 27 | Compressor | 1 | | | |

Exploded Views and Parts List

Outdoor unit AUS-12C53F150Px

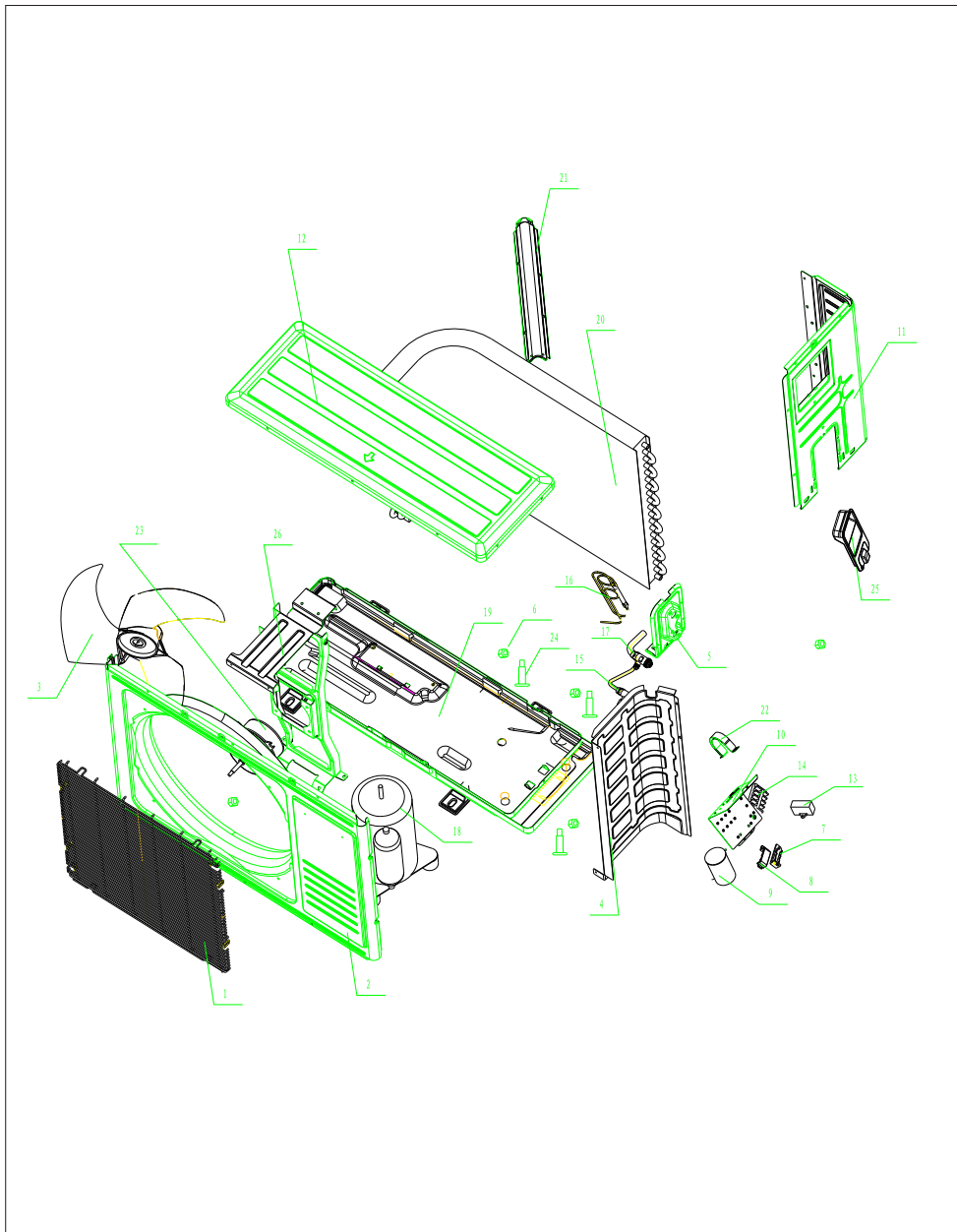

Exploded Views and Parts List

Outdoor unit AUS-12C53F150Px

| No. | English Part Name | Quantity | No. | English Part Name | Quantity |
|------------|-----------------------------|-----------------|------------|--------------------------|-----------------|
| 1 | Air outlet grille | 1 | | | |
| 2 | Front panel | 1 | | | |
| 3 | Outdoor unit fan | 1 | | | |
| 4 | Partition | 1 | | | |
| 5 | Valve board | 1 | | | |
| 6 | Compressor screw | 3 | | | |
| 7 | Power supply cord fixs | 1 | | | |
| 8 | Power supply cord clip | 1 | | | |
| 9 | Capacitor for compressor | 1 | | | |
| 10 | Electrical install board | 1 | | | |
| 11 | Right side board | 1 | | | |
| 12 | Top cover | 1 | | | |
| 13 | fan motor capacitor | 1 | | | |
| 14 | Outdoor unit terminal block | 1 | | | |
| 15 | High pressure valve | 1 | | | |
| 16 | Capillary assembly | 1 | | | |
| 17 | Low pressure valve | 1 | | | |
| 18 | Compressor | 1 | | | |
| 19 | Bottom board | 1 | | | |
| 20 | Condenser | 1 | | | |
| 21 | Uphold board | 1 | | | |
| 22 | Capacitor fixing clip | 1 | | | |
| 23 | Fan motor(outdoor) | 1 | | | |
| 24 | Fan screw nut M8 | 3 | | | |
| 25 | Right handle | 1 | | | |
| 26 | Outdoor fan motor supporter | 1 | | | |

Exploded Views and Parts List

Outdoor unit AUS-12H53F150Px

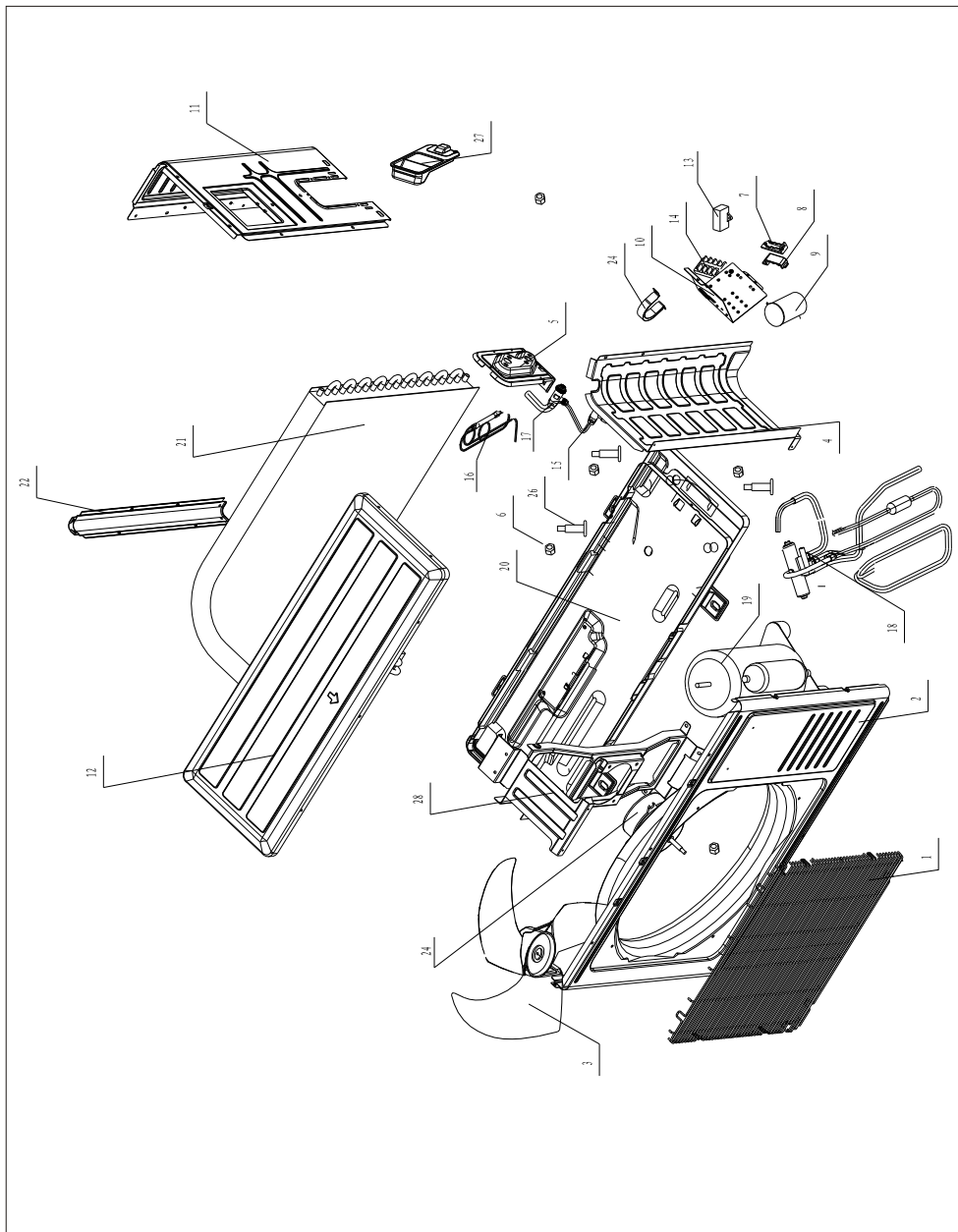

Exploded Views and Parts List

Outdoor unit AUS-12H53F150Px

| No. | English Part Name | Quantity | No. | English Part Name | Quantity |
|-----|-----------------------------|----------|-----|-------------------|----------|
| 1 | Air outlet grille | 1 | | | |
| 2 | Front panel | 1 | | | |
| 3 | Outdoor unit fan | 1 | | | |
| 4 | Partition | 1 | | | |
| 5 | Valve board | 1 | | | |
| 6 | Compressor screw | 3 | | | |
| 7 | Power supply cord fixs | 1 | | | |
| 8 | Power supply cord clip | 1 | | | |
| 9 | Capacitor for compressor | 1 | | | |
| 10 | Electrical install board | 1 | | | |
| 11 | Right side board | 1 | | | |
| 12 | Top cover | 1 | | | |
| 13 | fan motor capacitor | 1 | | | |
| 14 | Outdoor unit terminal block | 1 | | | |
| 15 | High pressure valve | 1 | | | |
| 16 | Capillary assembly | 1 | | | |
| 17 | Low pressure valve | 1 | | | |
| 18 | Four way valve | 1 | | | |
| 19 | Compressor | 1 | | | |
| 20 | Bottom board | 1 | | | |
| 21 | Condenser | 1 | | | |
| 22 | Uphold board | 1 | | | |
| 23 | Capacitor fixing clip | 1 | | | |
| 24 | Fan screw nut M6 | 1 | | | |
| 25 | Fan screw nut M8 | 3 | | | |
| 26 | Right handle | 1 | | | |
| 27 | Outdoor fan motor supporter | 1 | | | |

Wiring Diagrams

Indoor unit AUS-07H53F010Px AUS-12H53F150Px
 AUS-09H53F010Px AUS-12H53F110Px

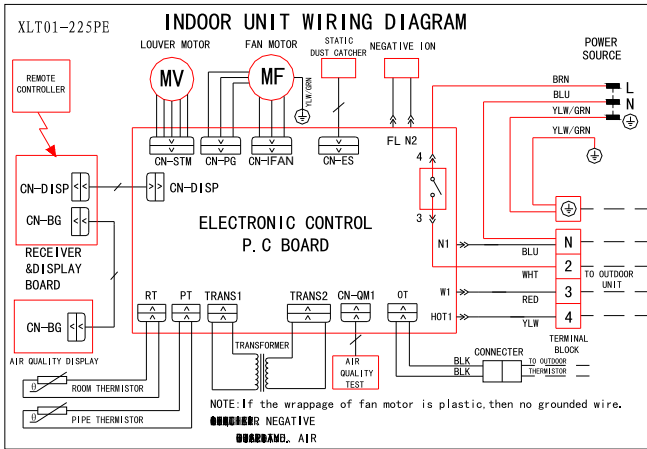

Outdoor unit AUS-07H53F010Px AUS-12H53F110Px
 AUS-09H53F010Px

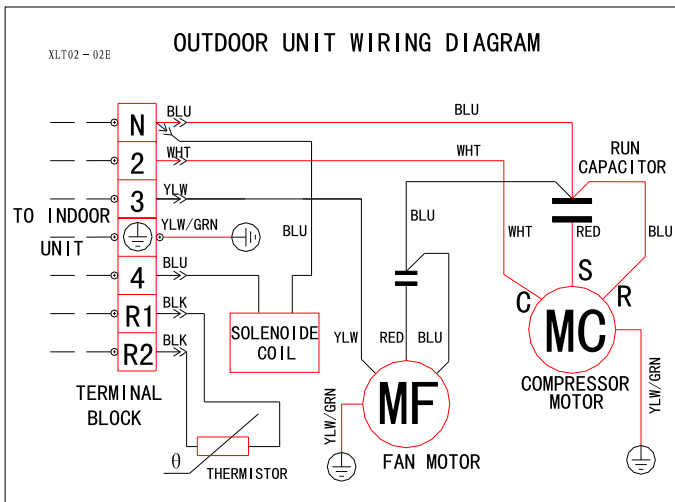

Wiring Diagrams

Indoor unit AUS-07C53F010Px AUS-09C53F010Px AUS-12C53F150Px

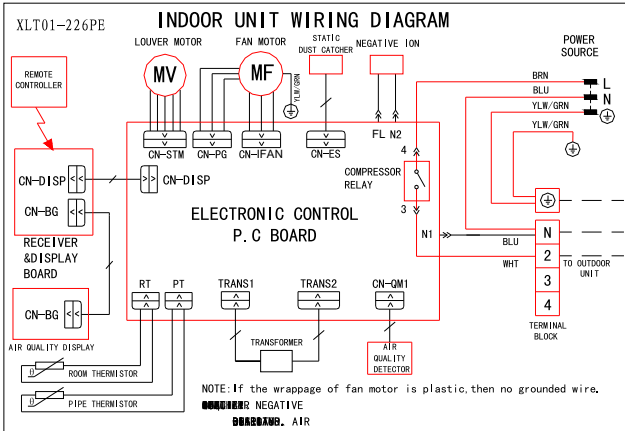

Outdoor unit AUS-09C53F010Px AUS-07C53F010Px AUS-12C53F150Px

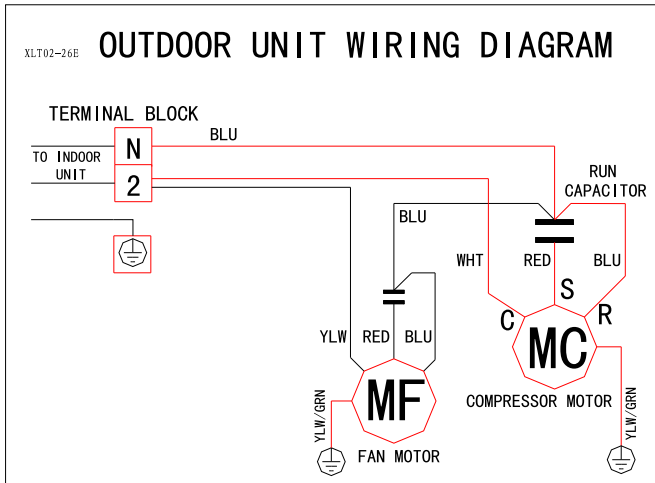

Wiring Diagrams

Outdoor unit AUS-12H53F150Px

